

KNIGHT

PROVEN INNOVATORS
of Material Handling Systems



▶ Smart *Cart*

Customize Your Cart...

Detail of the roll handling end effector.



Roll handler with manual rotate and custom angled legs for unloading pallets.

A new addition to the Knight Industries product line, the Smart Cart is designed to be customized to handle a wide variety of material handling needs.

Each cart is tailored to the customer's specific application. The Smart Cart is ideal when an off the shelf cart will not work with your application.

Cart Options:

- End Effector
- Overall Height
- Lift Height
- Legs (Standard, Low Profile or Custom)
- Base Size

Knight Industries can design and build a custom end effector for your application. Contact your Knight Industries Representative to discuss your application.



Standard Legs

Cart Features:

- Easy to Operate
- Capacities Up to 400 lbs (181.4 kg)
- Easy Maneuverability
- Maintenance Free Batteries
- Built-in Charger
- Low Maintenance
- Delivered Fully Assembled
- Digital Voltage Display
- Travel Limit Switches



Low Profile Legs

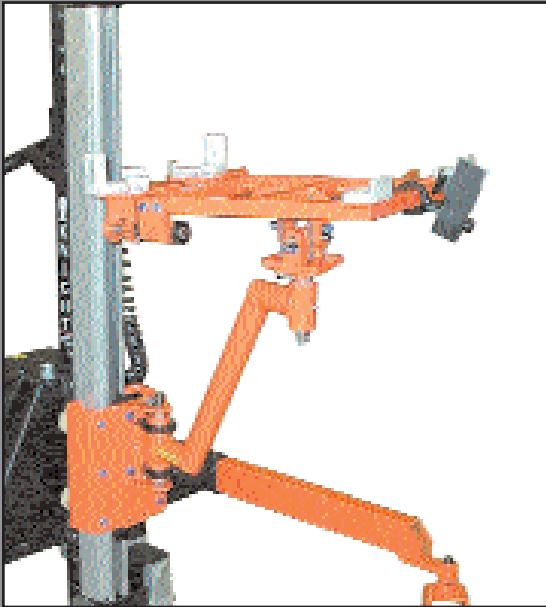

End effector for positioning a fuel tank onto a vehicle.



End effector for positioning an exhaust system onto a vehicle.



Roll Handler with manually operated rotate and push off device.



Probe with roller bearing end.



Fork end effector.

Specifications

Standard Cart Part Number	Low Profile Cart Part Number	Dimensions in. [mm]			
		Leg Length	Base Width	Overall Height*	Travel**
SCS435266	LSCS435266	35 [889]	26 [660]	72 [1828]	49 [1245]
SCS435267	LSCS435267	35 [889]	26 [660]	84 [2133]	61 [1549]
SCS435268	LSCS435268	35 [889]	26 [660]	96 [2438]	73 [1854]
SCS435316	LSCS435316	35 [889]	31 [787]	72 [1828]	49 [1245]
SCS435317	LSCS435317	35 [889]	31 [787]	84 [2133]	61 [1549]
SCS435318	LSCS435318	35 [889]	31 [787]	96 [2438]	73 [1854]
SCS435366	LSCS435366	35 [889]	36 [914]	72 [1828]	49 [1245]
SCS435367	LSCS435367	35 [889]	36 [914]	84 [2133]	61 [1549]
SCS435368	LSCS435368	35 [889]	36 [914]	96 [2438]	73 [1854]
SCS440266	LSCS440266	40 [1016]	26 [660]	72 [1828]	49 [1245]
SCS440267	LSCS440267	40 [1016]	26 [660]	84 [2133]	61 [1549]
SCS440268	LSCS440268	40 [1016]	26 [660]	96 [2438]	73 [1854]
SCS440316	LSCS440316	40 [1016]	31 [787]	72 [1828]	49 [1245]
SCS440317	LSCS440317	40 [1016]	31 [787]	84 [2133]	61 [1549]
SCS440318	LSCS440318	40 [1016]	31 [787]	96 [2438]	73 [1854]
SCS440366	LSCS440366	40 [1016]	36 [914]	72 [1828]	49 [1245]
SCS440367	LSCS440367	40 [1016]	36 [914]	84 [2133]	61 [1549]
SCS440368	LSCS440368	40 [1016]	36 [914]	96 [2438]	73 [1854]

* Overall height is measured from the ground to the top of the mast.

** The travel of the cart is figured with the following formula:

$$\text{Mast Height} - 23" [584 \text{ mm}] = \text{Travel}$$

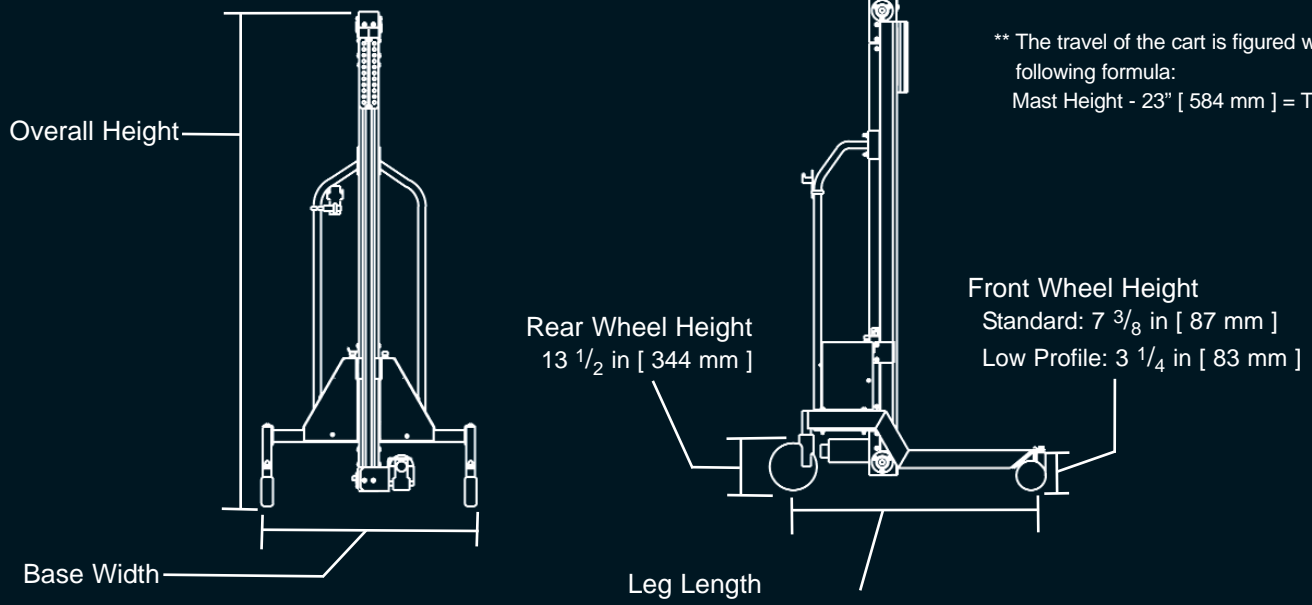

Max Capacity	400 lb [181.4 kg]
Battery Type	Lead Gel Cell Batteries
Battery Capacity	24V 28 AH / 56 AH
Battery Charger Output	24V 10 Amp 5A/5A
Charge Time	1 to 2 Hours
Lift Speed	7.5 inches / second

