

KNIGHT

PROVEN INNOVATORS
of Material Handling Systems

Tables / **Shuttles** / Carts



Lift Tables

The Knight lift table raises loads to the proper ergonomic height for the operator.

Available Options:

- Steel Riser
- Pit Mounted (Angled Toe Guards, External Mounted Pit Guards or Auto Shut-off Safety Bars are required)
- Corner Gusset Tabs (no extra charge)
- Ratchet Safety Stops
- Bellows Skirting

Control Options:

- Free Standing Pedestal Control
- Foot Control
- Bolt on Hand Control

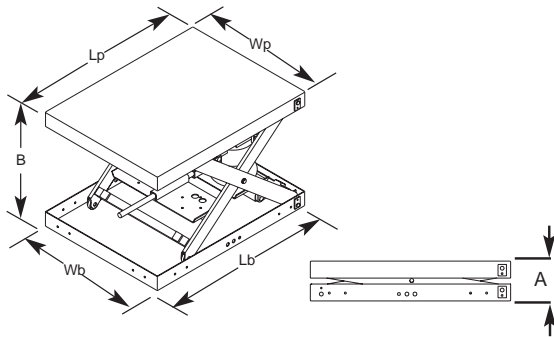

Model	Capacity lbs [kg]	Closed (A) in [mm]	Extended (B) in [mm]	Base Size (Wb x Lb) in [mm]	Platform Size (Wp x Lp) in [mm]
L3636-2000	2000 [907]	10 [254]	24 [588]	28 x 36 [711 x 914]	28 x 36 [711 x 914] to 36 x 44 [914 x 914]
L4860-2000	2000 [907]	10 [254]	37 [940]	28 x 50 [711 x 1270]	28 x 50 [711 x 1270] to 48 x 60 [1219 x 1524]
L4860-4000	4000 [1814]	10 [254]	37 [940]	38 x 50 [965 x 1270]	38 x 50 [965 x 1270] to 48 x 60 [1219 x 1524]
L4860-8000	8000 [3629]	10 [254]	37 [940]	38 x 50 [965 x 1270]	38 x 50 [965 x 1270] to 48 x 60 [1219 x 1524]
L5684-4000	4000 [1814]	11 [279]	45 [1143]	42 x 62 [1067 x 1575]	42 x 62 [711 x 914] to 56 x 84 [1422 x 2184]
L5684-6000	6000 [2722]	11 [279]	45 [1143]	42 x 62 [1067 x 1575]	42 x 62 [711 x 914] to 56 x 86 [1422 x 2184]

Lift and Rotate Tables

Knight rotate tables are available with our exclusive yoke supported caster bearings, or a maintenance free 20,000 lb [9072 kg] capacity mechanical thrust bearing.

Available Options:

- Steel Riser
- Pit Mounted (Angled Toe Guards, External Mounted Pit Guards or Auto Shut-off Safety Bars are required)
- Corner Gusset Tabs (no extra charge)
- Ratchet Safety Stops
- Bellows Skirting

Control Options:

- Free Standing Pedestal Control
- Foot Control
- Bolt on Hand Control

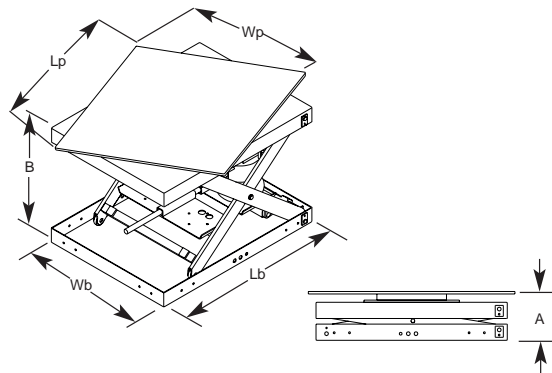
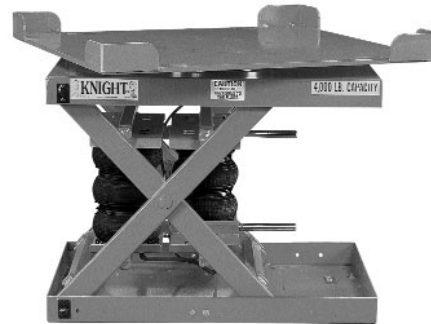

Model	Capacity lbs [kg]	Closed (A) in [mm]	Rotation	Extended (B) in [mm]	Base Size (Wb x Lb) in [mm]	Platform Size (Wp x Lp) in [mm]
LR4860C-2000	2000 [907]	12 [305]	360°	39 [991]	28 x 50 [711 x 1270]	43 x 43 [1092 x 1092] to 48 x 60 [1219 x 1524]
LR4860C-4000	4000 [1814]	12 [305]	360°	39 [991]	28 x 50 [711 x 1270]	43 x 43 [1092 x 1092] to 48 x 60 [1219 x 1524]
LR4860R-4000	4000 [1814]	13 [330]	360°	40 [1016]	38 x 50 [965 x 1270]	38 x 50 [965 x 1270] to 48 x 60 [1219 x 1524]
LR4860R-8000	8000 [3629]	13 [330]	360°	40 [1016]	38 x 50 [965 x 1270]	38 x 50 [965 x 1270] to 48 x 60 [1219 x 1524]
LR5684R-4000	4000 [1814]	14 [356]	360°	48 [1219]	42 x 62 [1067 x 1575]	42 x 62 [1067 x 1575] to 56 x 84 [1422 x 2134]
LR5684R-6000	6000 [2722]	14 [356]	360°	48 [1219]	42 x 62 [1067 x 1575]	42 x 62 [1067 x 1575] to 56 x 84 [1422 x 2134]

With a collapsed height of nearly half our standard table the low profile table is able to accommodate a wider range of operator heights.

Available Options:

- Lock-out Valves
- Bellows Skirting
- Corner Gusset Tabs

Control Options:

- Free Standing Pedestal Control
- Foot Control

Low Profile Lift Table

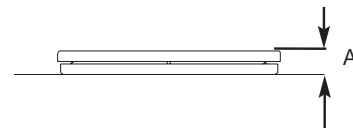
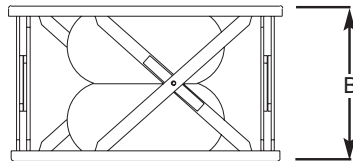
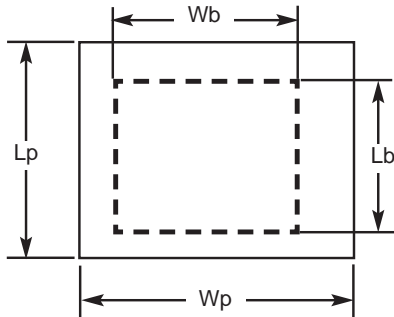

Model	Capacity Lbs [kg]	Closed A in [mm]	Extended B in [mm]	Platform Size (Wp x Lp) in [mm]	Base Size (Wb x Lb) in [mm]
LPL4353-6000	6000 [2722]	4.5 [114]	30 [762]	43 x 53 [1092 x 1346] to 56 x 60 [1422 x 1524]	42 x 52 [1067 x 1321]

Low Profile Lift & Rotate Table

Our low profile lift and rotate table custom air bag allows

Available Options:

- Lock-out Valves
- Bellows Skirting
- Corner Gusset Tabs

Control Options:

- Free Standing Pedestal Control
- Foot Control

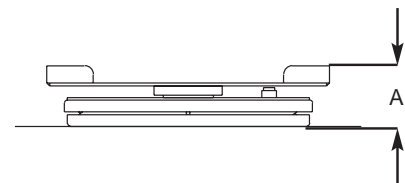
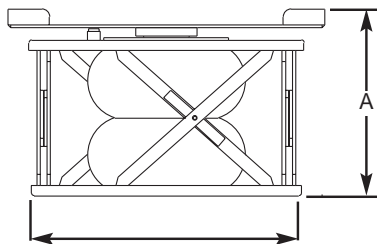
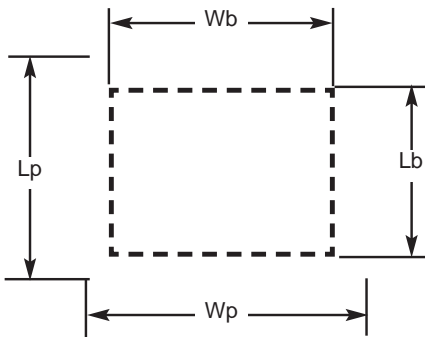
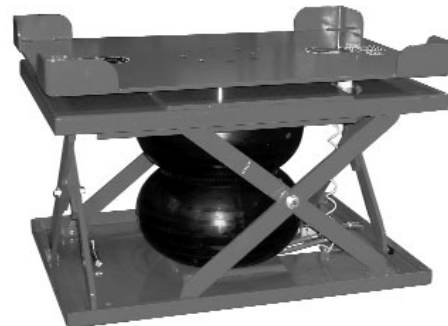

Model	Capacity Lbs [kg]	Closed A in [mm]	Extended B in [mm]	Platform Size (Wp x Lp) in [mm]	Base Size (Wb x Lb) in [mm]
LPLR4353-6000	6000 [2722]	7.5 [191]	30 [762]	38 x 38 [965 x 965] to 56 x 60 [1422 x 1524]	42 x 52 [1067 x 1321]

Lift & Tilt Tables



The combination of the lift and tilt function gives the operator twice the ergonomic benefit.

Available Options:

- Steel Riser
- Pit Mounted (Angled Toe Guards, External Mounted Pit Guards or Auto Shut-off Safety Bars are required)
- Corner Gusset Tabs (no extra charge)
- Ratchet Safety Stops
- Bellows Skirting
- Motion Stabilizer

Control Options:

- Free Standing Pedestal Control

Control

- Bolt on Hand Control
- Foot Control

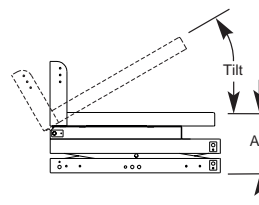
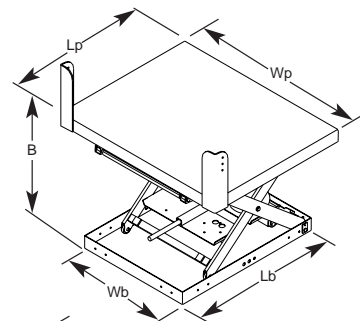

Model	Capacity lbs [kg]	Closed (A) in [mm]	Extended (B) in [mm]	Tilt	Base Size (Wb x Lb) in [mm]	Platform Size (Wp x Lp) in [mm]
LT4860-4000	4000 [1814]	16 [406]	40 [1016]	0° - 40°	38 x 50 [965 x 1270]	38 x 50 [965 x 1270] to 60 x 48 [1524 x 1219]
LT4860-6000	6000 [2722]	16 [406]	40 [1016]	0° - 40°	38 x 50 [965 x 1270]	38 x 50 [965 x 1270] to 60 x 48 [1524 x 1219]
LT5684-4000	4000 [1814]	17.25 [438]	50 [1270]	0° - 40°	42 x 62 [1067 x 1575]	42 x 62 [1066 x 1575] to 84 x 56 [2134 x 1422]
LT5684-6000	6000 [2722]	17.25 [4.38]	50 [1270]	0° - 40°	42 x 62 [1067 x 1575]	42 x 62 [1066 x 1575] to 84 x 56 [2134 x 1422]

Tilt Tables



By tilting the container forward our tilt tables position the dunnage for easy loading or unloading.

Available Options:

- Steel Riser
- Motion Stabilizer
- Ratchet Safety Stops
- Bellows Skirting

Control Options:

- Free Standing Pedestal Control
- Foot Control
- Bolt on Hand Control

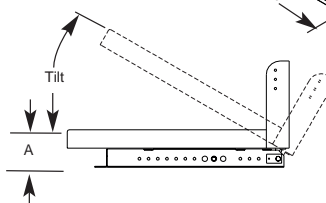
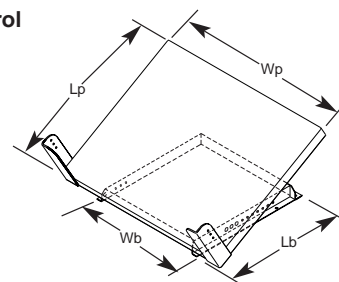

Model	Capacity lbs [kg]	Tilt	Height at 0° (A) in [mm]	Platform Size (Wp x Lp) in [mm]	Base Size (Wb x Lb)
T4860-4000	4000 [1814]	0° - 40°	8.5 [216]	36 x 36 [914 x 914] to 60 x 48 [1524 x 1219]	Proportional to Platform
T4860-8000	8000 [3629]	0° - 40°	8.5 [216]	36 x 36 [914 x 914] to 60 x 48 [1524 x 1219]	
T5684-4000	4000 [1814]	0° - 40°	8.5 [216]	60 x 48 [1524 x 1219] to 84 x 56 [2134 x 1422]	
T5684-8000	8000 [3629]	0° - 40°	8.5 [216]	60 x 48 [1524 x 1219] to 84 x 56 [2134 x 1422]	

Slide-Tilt Tables

The Knight slide-tilt table maintains the clearance on the unload side of the table with our patented slide and tilt motion.

Available Options:

- Steel Riser
- Bellows Skirting

Control Options:

- Free Standing Pedestal Control
- Foot Control
- Bolt on Hand Control

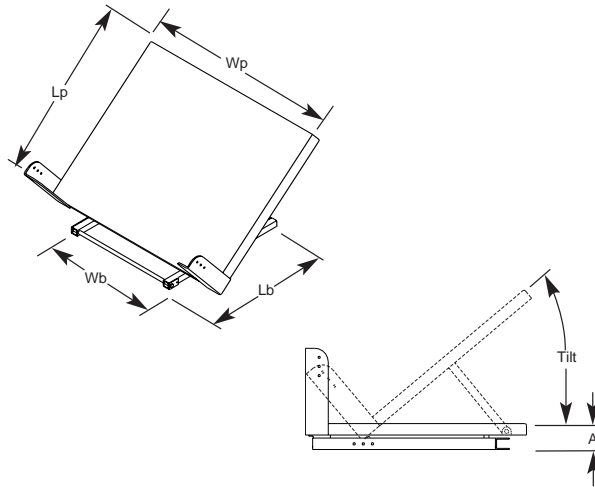

Model	Capacity lbs [kg]	Height at 0° (A) in [mm]	Tilt	Platform Size (Wp x Lp) in [mm]	Base Size (Wb x Lb)
ST5560-4000	4000 [1814]	10 [254]	0° - 40°	36 x 55 [914 x 1397] to 60 x 55 [1524 x 1397]	Proportional to Platform
ST5560-8000	8000 [3629]	10 [254]	0° - 40°	36 x 55 [914 x 1397] to 60 x 55 [1524 x 1397]	
ST5684-4000	4000 [1814]	10 [254]	0° - 40°	60 x 55 [1524 x 1397] to 84 x 56 [1524 x 1397]	
ST5684-8000	8000 [3629]	10 [254]	0° - 40°	60 x 55 [1524 x 1397] to 84 x 56 [1524 x 1397]	

Load Sensors

Knight's patented air reservoir system maintains loads at an ergonomic working height during varying weight loads.

Available Options:

- Steel Riser
- Pit Mounted (Angled Toe Guards, External Mounted Pit Guards or Auto Shut-off Safety Bars are required)
- Rotating Top Plate utilizing Caster Wheels only
- Gusset Tabs (no extra charge)
- 90° Spring Detent
- Thumbscrew Lock
- Bellows Skirting

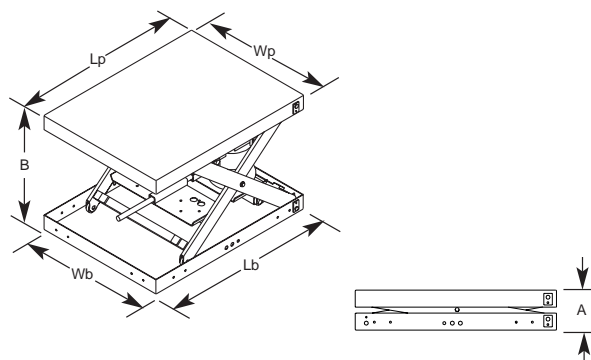

Model	Capacity lbs [kg]	Closed (A) in [mm]	Extended (B) in [mm]	Rotation	Base Size (Wb x Lb) in [mm]	Platform Size (Wp x Lp) in [mm]
LS4343-4500	4500 [2041]	10 [254]	34 [864]	N/A	28 x 50 [711 x 1270]	28 x 50 [711 x 1270] to 48 x 60 [1219 x 1524]
LS4343C-4500	4500 [2041]	12 [305]	36 [914]	360°	28 x 50 [711 x 1270]	43 x 43 [1092 x 1092] to 48 x 60 [1219 x 1524]

Double Scissor Lift Tables

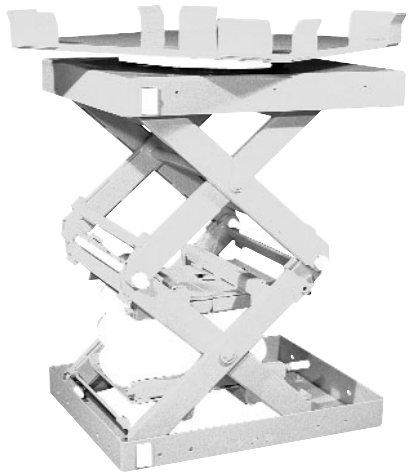

Model	Capacity lbs [kg]	Closed (A) in [mm]	Extended (B) in [mm]	Base Size (Wb x Lb) in [mm]	Platform Size (Wp x Lp) in [mm]
DSL4860-1000	1000 [454]	15 [381]	75 [1905]	38 x 50 [956 x 1270]	42 x 50 [1067 x 1270] to 48 x 60 [1219 x 1524]
DSL4860-2000	2000 [904]	15 [381]	75 [1905]	38 x 50 [956 x 1270]	42 x 50 [1067 x 1270] to 48 x 60 [1219 x 1524]
DSL4850C-1000	1000 [454]	17 [432]	77 [1956]	38 x 50 [956 x 1270]	42 x 50 [1067 x 1270] to 48 x 60 [1219 x 1524]
DSL4850R-1000	1000 [454]	18 [457]	78 [1981]	38 x 50 [956 x 1270]	42 x 50 [1067 x 1270] to 48 x 60 [1219 x 1524]

The Knight double scissor lift table is an excellent choice when extra lift is needed to raise loads to a safe ergonomic height for the operator.

Available Options:

- Pit Mounted (Angled Toe Guards, External Mounted Pit Guards or Auto Shut-off Safety Bars are required)
- Corner Gusset Tabs (no extra charge)
- Ratchet Safety Stops
- Bellows Skirting

Control Options:

- Free Standing Pedestal Control
- Foot Control
- Bolt on Hand Control

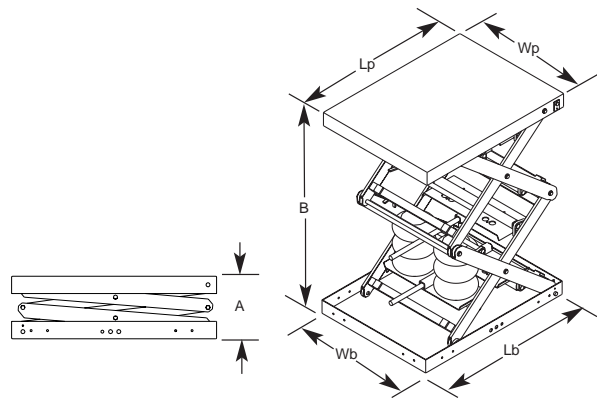

Corner Tilt Tables



The Knight corner tilt table tilts loads to a safe ergonomic height, positioning the pallet or basket to the operators work level.

Available Options:

- Steel Riser
- Bellows Skirting
- Motion Stabilizer

Control Options:

- Free Standing Pedestal Control
- Foot Control
- Bolt on Hand Control

Model	Capacity lbs [kg]	Closed (A) in [mm]	Tilt	Base Size (Wb x Lb) in [mm]	Platform Size (Wp x Lp) in [mm]
CT3636-4000	4000 [1814]	8.5 [216]	0° - 40°	36 x 36 [914 x 914]	36 x 36 [914 x 914]
CT4848-4000	4000 [1814]	4000 [1814]	0° - 40°	48 x 48 [1219 x 1219]	48 x 48 [1219 x 1219]
CT6060-4000	4000 [1814]	4000 [1814]	0° - 40°	60 x 60 [1524 x 1524]	60 x 60 [1524 x 1524]

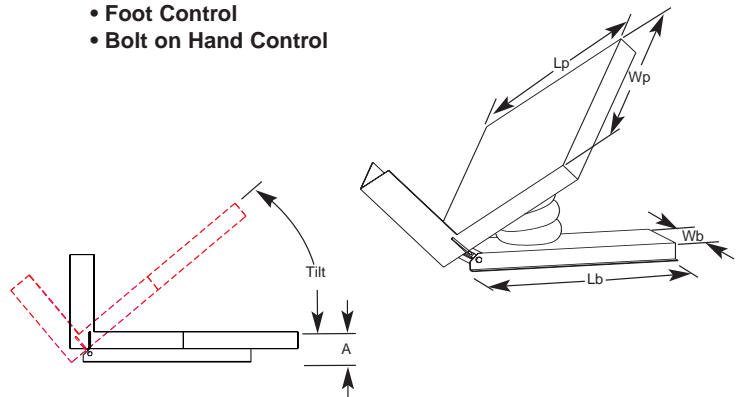

Lift Zero Loaders

Knight zero loaders combine the convenience of ground level loading with the footprint of a standard lift table. Designed specifically for pallet jacks, push carts or taller hard to reach container applications. Allows the operator to work in a safe ergonomic range, increasing productivity while reducing fatigue.

- 4000 lbs [1814 kg] capacity
- 24" [61 cm] standard lift
- Free standing pedestal or foot control
- Narrow foot print
- Various heights available
- Pneumatically powered



Zero Loaders

Knight zero loaders are designed for ground level loading with a pallet jack when fork truck access is limited.

Available Options:

- Motion Stabilizer for Tilt
- Bellows Skirting

Control Options:

- Free Standing Pedestal Control
- Foot Control
- Bolt on Hand Control

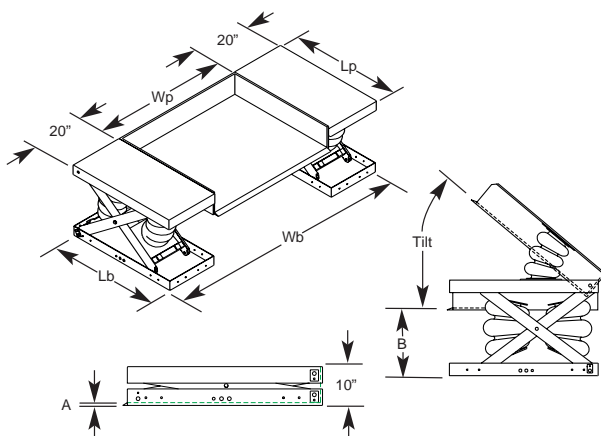
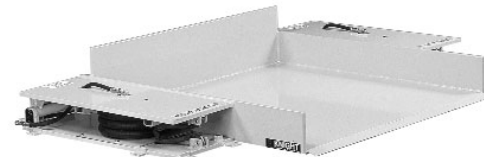

Model	Capacity lbs [kg]	Closed (A) in [mm]	Extended (B) in [mm]	Tilt	Platform Size (Wp x Lp) in [mm]
TZ4860-2000	2000 [907]	.75 [19]	N/A	0° - 40°	Up to 60 x 48 [1524 x 1219]
TZ4860-4000	4000 [1814]	.75 [19]	N/A	0° - 40°	Up to 60 x 48 [1524 x 1219]
TZ4860-6000	6000 [2722]	.75 [19]	N/A	0° - 40°	Up to 60 x 48 [1524 x 1219]
LZ4860-2000	2000 [907]	.75 [19]	24 [610]	N/A	Up to 60 x 48 [1524 x 1219]
LZ4860-4000	4000 [1814]	.75 [19]	24 [610]	N/A	Up to 60 x 48 [1524 x 1219]
LZ4860-6000	6000 [2722]	.75 [19]	24 [610]	N/A	Up to 60 x 48 [1524 x 1219]
LTZ4860-2000	2000 [907]	.75 [19]	24 [610]	0° - 40°	Up to 60 x 48 [1524 x 1219]
LTZ4860-4000	4000 [1814]	.75 [19]	24 [610]	0° - 40°	Up to 60 x 48 [1524 x 1219]
LTZ4860-6000	6000 [2722]	.75 [19]	24 [610]	0° - 40°	Up to 60 x 48 [1524 x 1219]

Platform Lifts

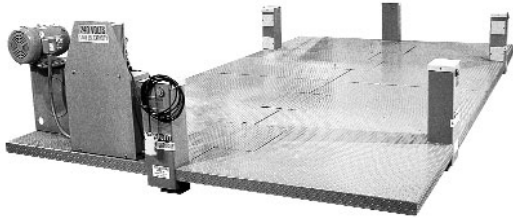

This lift positions the operator in an ergonomic manner.

Available Options:

- Adjustable Leg Cylinders for Variable Closed Height
- Pit Mounted (Angled Toe Guards, External Mounted Pit Guards or Auto Shut-off Safety Bars are required)
- Air or Electric Driven Hydraulic System
- Diamond Plate Deck
- Up to 18 ft [5486 mm] Long
- Up to 2000 lb [904 kg] Capacity
- Bellows Skirting

Control Options:

- Hand Held Push button
- Pedestal Mounted Push Button
- Foot Pedal

Turntables

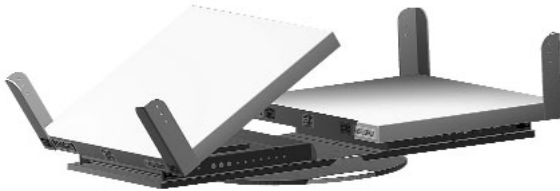

Available Options:

- Tilt Decks
- Straight Lift
- Lift and Rotate
- Motion Stabilizers
- Ratchet Safety Stops

Control Options:

- Free Standing Pedestal Control
- Foot Control
- Bolt on Hand Control

Lift / Rotating Carts



Available Options:

- 90° detents on rotating units
- Gusset Tabs (no extra charge)

Control Options:

- Bolt-On Push Button
- Pedestal Mounted Push Button
- Foot Pedal

Controls

Features:

- 2,000 psi [138 bar] steel braided hydraulic hoses and fittings
- All steel construction provides long lasting durability
- Three position closed center valve with poppet internals and detent on down stroke
- Available in Pedestal or foot controls



Bellows Skirting

- Manufactured from tough, extra heavy duty 23 ounce vinyl coated polyester
- Steel rods sewn in every other fold add strength and uniformity to shape
- Top of bellows is made of heavy duty mesh allowing the influx or expulsion of air created by the tables movements

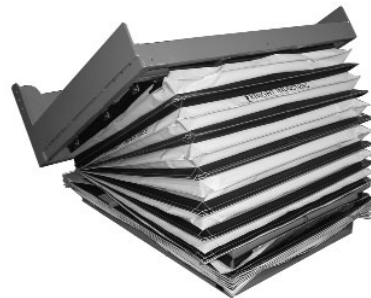

Motion Stabilizer

Motion stabilizers help keep loads traveling upward and downward in a smooth, consistent manner. They are typically used for loads greater than 4,000 lbs [1814 kg] and are optional equipment for many Knight tables.



Steel Risers

All steel reinforced construction ensures a safe and sturdy mounting base. Standard sizes are available and include a 10 in. [254 mm] base height. Other sizes are available and built upon request.

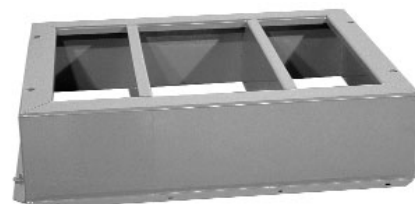

Powered Accumulators

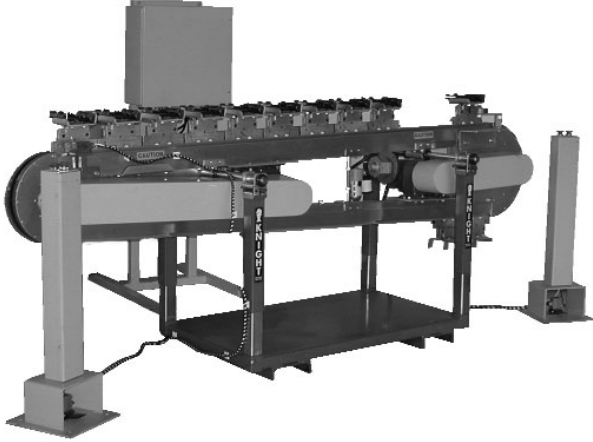

The Knight accumulator was developed to transfer parts between two workstations and offer an accumulation of parts at the off-load end. A standard system has two low maintenance air motor drives with dual speed reducers. Each end is independently powered for complete operator control.

- Up to 50 lbs/ft [23 kg] loading capacity
- Available as fully automated or operator initiated system
- Tandem/dual track system
- Up to 2 transfer trolleys per foot
- Floor mounted or overhead styles

Gravity Over-Under



Knight Industries gravity over-under is an efficient way to transfer parts between workstations for assembly applications. No power source is required, making it a very cost effective and virtually maintenance free system. For specific information on application alternatives contact your Knight representative.

- Low friction trolleys on extruded aluminum surfaces
- Overhead or floor support stand
- Standard lengths are 5 ft [60 in] to 20 ft [240 in]
- No power source required
- All hangers/nesting fixtures are specifically engineered to fit the part being transferred